

## Introduction

Any electrical or electronic equipment that is designed without including circuit protection is an accident waiting to happen. Under normal operating conditions, this may not appear to be a problem. However, normal operating conditions are not always guaranteed. Under strained or heavy use, a motor and/or another load-generating component within the equipment will draw additional current from the power source; when this happens, the equipment's wires and/or components will overheat and may ultimately burn up. Also, power surges and short circuits in unprotected equipment can cause extensive damage to the equipment and to the conductors leading to the equipment.

In addition to protecting the equipment, the entire electrical system including the control switches, wires, and power source must be protected from faults. A circuit protection device should be employed at any point where a conductor size changes. Many electronic circuits and components like transformers have a lower overload withstand threshold level than conductors such as wires and cables. These components require circuit protection devices featuring very fast overload sensing and opening capabilities.

Specifying a circuit protection device for an application is not a difficult task, but it will require some thought. If electrical and electronic equipment is designed with over-specified circuit protection devices they will be vulnerable to the damaging effects of power surges and the catastrophic results of a fire; while using under-specified circuit protection devices will result in nuisance tripping.

Before specifying a circuit protection device, equipment designers should evaluate the load characteristics during equipment startup and at normal operation. Many types of equipment will produce startup inrush current, or surges. In these cases, circuit breakers with the appropriate time delay should be selected. The time delay specified should slightly exceed the duration of the surge.

Before specifying a circuit protection device, an equipment designer should also consider the following:

- Applied voltage rating (AC or DC)
- Single phase, multi-phase / number of poles
- Applicable national electric codes and safety regulatory agency standards
- Interrupting (short circuit) capacity
- Mounting requirements and position / enclosure size constraints

The short circuit capacity of a circuit protection device should be greater than the circuit's available short circuit fault current. Available short circuit current is the maximum RMS current that would be present if all the conductors were to be connected directly to the fault location. In reality, this is not the case. The actual short circuit current is much less than the available short circuit current. The actual short circuit current is reduced due to the combined impedance of the conductors, the size of the transformer and other current restricting components within the circuit.

The application's environmental conditions must be considered when selecting the proper circuit protection device. Excessive temperature, humidity, severe vibration and shock can cause adverse performance characteristics in many types of circuit protection devices. For instance, a fuse element is less reliable when it is hot than when it is cold.

The mounting position of a hydraulic/magnetic circuit breaker is critical to its performance. A standard hydraulic/magnetic circuit breaker should be mounted on a vertical panel as gravity will influence the "must hold" and "must trip" calibration. It is possible to specify the breaker for use in other mounting positions, however, special factory calibration will be required to prevent adverse performance characteristics.

## Regulatory Agencies

Most countries have regulatory agencies that determine the safety and performance standards required for products used in that country. Carling Technologies' circuit breakers are tested and have been certified by the most widely recognized of these agencies, including Underwriters Laboratories (UL) in the United States; Canadian Standards Association (CSA) in Canada; TUV Rheinland/Berlin-Brandenburg (TUV) and Verband Deutscher Elektrotechniker (VDE) in Germany.

### UL Recognized/UL1077 Recognized

UL Recognition covers components, which are incomplete or restricted in performance capabilities. These components will later be used in complete end products or systems Listed by UL. These Recognized components are not intended for separate installation in the field, they are intended for use as components of complete equipment submitted for investigation to UL.

Carling Technologies offers circuit breakers which are classified as supplementary circuit protectors and are Recognized under the UL Components Recognition Program as Protectors, Supplementary, UL Standard 1077. A UL 1077 Recognized supplementary circuit protector must have a Listed overcurrent device as a "back up". Carling's M, A, B, C, D and E circuit breakers offer UL 1077 Recognition.

### UL Listed/UL 489 Listed

UL Listing indicates that samples of the circuit breaker as a complete product have been tested by UL to nationally recognized safety standards and have been found to be free from reasonably foreseeable risks of fire, electric shock and related hazards, and that the product was manufactured under UL's Follow-Up Services program.

Carling Technologies offers branch circuit breakers that are UL 489 Listed. Branch circuit breakers are classified as a final overcurrent device dedicated to protecting the branch circuit and outlet(s). They do not require an additional "back up" overcurrent device wired in series to protect a circuit. Carling's C, E and F-Series circuit breakers offer UL489 Listing. In addition, they are UL489A Listed for Telecom industry.

### UL1500 (MARINE)

UL1500 refers to products and components classified as ignition-protected, and are intended to be installed and used in accordance with applicable requirements to the U.S. Coast Guard, the Fire Protection Standard for Pleasure and Commercial Motor Craft, ANSI/NFPA No. 302, and the American Boat and Yacht Council, Incorporated. Specially constructed versions of Carling Technologies' A, B and C-Series circuit breakers meet this standard.

### CSA

The CSA (Canadian Standards Association) is the closest in concept and nature to UL of any group outside of the United States. Their standards and requirements are often almost identical to corresponding UL standards. CSA publishes their standards for most circuit protection devices as separate sections of CSA Standard C22.2 that in turn, forms a part of the Canadian Electrical Code. All of Carling Technologies' circuit protection products meet the applicable requirements of CSA Standard C22.2.

### CUL

A cUL mark on a product means that samples of the product have been evaluated to the applicable Canadian standards and codes by Underwriters Laboratories Inc.

### VDE and TUV

There are two German government approved independent agencies, VDE (Verband Deutscher Elektrotechniker), and TUV (Technischer Überwachungs-Verein). In the circuit protection field, outside of the U.S.A. and Canada, VDE is the best known certification mark. VDE testing facilities are located in Germany.

TUV also performs testing and grants certification in accordance to the IEC/EN specifications. TUV's organization is made up of at least eleven geographically dispersed companies. At least two are located in the United States. This aids some U.S. manufacturers in getting "fast track" approval to a IEC/EN specifications. Carling's M, A, B, C, D and E-Series breakers have been certified to meet EN 60934 by VDE and TUV labs.

### CE MARKING

The European Union's (EU) approach to create single market access is based on four principles: harmonized directives, harmonized standards, harmonized conformity assessment procedures and CE marking. The CE marking is affixed to products indicating that the product conforms to relevant directives and standards. Various directives and standards contain the requirements for CE marking. The CE marking is primarily for market control by custom inspectors.

Before a manufacturer can affix the CE marking to their product they must complete the following steps:

1. Identify the applicable EU directive/standard
2. Perform the conformity assessment according to the applicable EU directive/standard
3. Establish a Technical File containing test reports, documentation, certificates, etc.
4. Prepare and sign a EU Declaration of Conformity

Many of Carling Technologies' circuit protection products are available with CE marking indicating conformance to Low Voltage Directive 73/23/EEC.

## Available Choices of Circuit Protection

Carling Technologies offers three types of circuit protection devices: thermal circuit protectors, hydraulic/magnetic circuit protectors/breakers and equipment leakage circuit breakers. This catalog features hydraulic/magnetic circuit protection and equipment leakage circuit breaker products. For details related to our thermal circuit protection product line, please see our thermal circuit protection catalog.

Thermal circuit protectors utilize a bimetallic strip electrically in series with the circuit. The heat generated by the current during an overload deforms the bimetallic strip and trips the breaker. Thermal protectors have a significant advantage over fuses in that they can be reset after tripping. They can also be used as the main ON/OFF switch for the equipment being protected. However, thermal breakers have some disadvantages. They are, in effect, "heat sensing" devices, and can be adversely affected by changes in ambient temperature. When operating in a cold environment, they will trip at a higher current level. When operating in a hot environment, they will "nuisance trip" at a lower current level resulting in unwanted equipment shut downs.

Hydraulic/magnetic circuit protectors/breakers provide highly precise, reliable and cost effective solutions to most design problems. They have the advantages of thermal breakers but none of their disadvantages. The hydraulic/magnetic circuit breaker is considered to be temperature stable and thus is not appreciably affected by changes in ambient temperature. Its over-current sensing mechanism reacts only to changes of current in the cir-

cuit being protected. It has no "warm-up" period to slow down its response to overload. It has no "cool-down" period after overload before it can be reset. The characteristics of a hydraulic/magnetic circuit breaker can be tailored in four separate areas: the desired circuit; the trip point (in amperes); the time delay (in seconds); and the inrush handling capacity of the breaker. These factors can be varied with relatively little impact on the short circuit capability of the breaker. Typically, hydraulic/magnetic circuit breakers are available with a choice of three different trip time, delay curves: slow, medium and long. These choices provide the designer with a high level of design flexibility when matching the breakers trip time delay curves to other circuit protection devices in a cascade, or discriminating circuit. In addition, special hi-inrush constructions are available for equipment with severe inrush characteristics.

Equipment leakage circuit breakers function as hydraulic/magnetic circuit breakers, offering customized overload and short circuit protection. In addition, they sense and guard against faults to ground using innovative electronics technologies. With the exception of small amounts of leakage, the current returning to the power supply will be equal to the current leaving the power supply. If the difference between the current leaving and returning through the earth leakage circuit breaker exceeds the leakage sensitivity setting, the breaker trips and its LED illuminates. The LED gives a clear indication that the trip occurred as a result of leakage to ground. This protection helps prevent serious equipment damage and fire.

## Carling Technologies' Hydraulic/Magnetic Circuit Breakers

Carling Technologies' hydraulic/magnetic circuit breakers are current sensing devices employing a time proven hydraulic magnetic design. Their precision mechanisms are temperature stable and are not adversely affected by temperature changes in their operating environment. As such, derating considerations due to temperature variations are not normally required, and heat-induced nuisance tripping is avoided.

### Features

- A trip-free mechanism, a safety feature, makes it impossible to manually hold the contacts closed during overcurrent or fault conditions.
- Worldwide safety agency approvals are available.
- Current ratings to 700 Amps and rated voltages to 600 VAC are available.
- A common trip linkage between all poles, another safety feature, ensures that an overload in one pole will trip all adjacent poles.
- Industry standard dimensions, mounting and current ratings provide maximum application versatility.
- Series trip, mid-trip and switch only (with or without auxiliary switch), remote shutdown, shunt trip, relay trip and dual coil circuit options are offered.
- Handle actuators, solid color rocker actuators, illuminated rocker actuators and the exclusive Visi-Rocker® two-color rocker actuators, allow design flexibility and contemporary panel styling.
- 35mm DIN Rail back panel mounting available for world market applications.

Typical Applications

Magnetic circuit breakers protect wiring, motors, generators, transformers, solid state systems, computers, telecommunications systems, micro-processors, peripheral and printing devices, office machines, machine tools, medical and dental equipment, instrumentation, vending machines, industrial automation and packaging systems, process control systems,

lamps, ballasts, storage batteries, linear and switching power supplies, as well as marine control panels and numerous other applications.

Generally, wherever precise and reliable circuit protection is required, a magnetic circuit breaker is specified.

What Makes a Magnetic Circuit Breaker Trip

The most common magnetic circuit breaker configuration is called "Series Trip". It consists of a current sensing coil connected in series with a set of contacts. (Fig. 1)

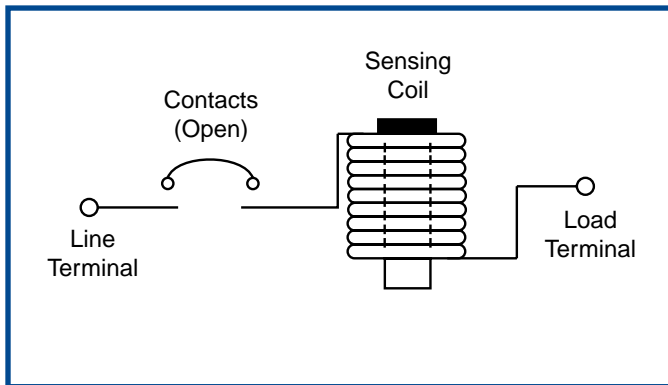

Figure 1

Inside the coil is a non-magnetic delay tube, housing a spring-biased, moving, magnetic core. An armature links the contacts to the coil mechanism, which functions as an electro magnet. When the contacts are open, there is no current flow through the circuit breaker, and no electro-magnetic energy is developed by the coil. When the contacts are closed, current flow begins. (Fig. 2)

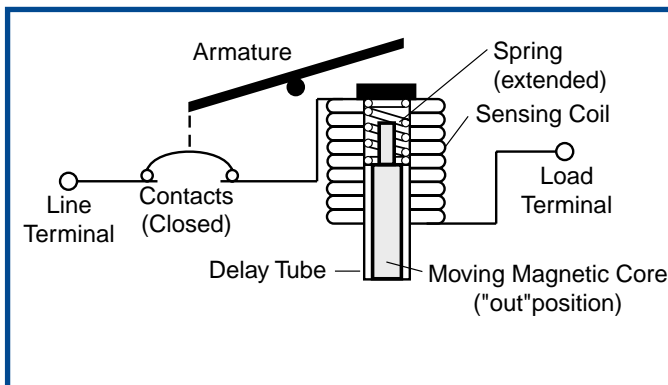

Figure 2 - Rated Current or Less

As the normal operating or "rated" current flows through the sensing coil, a magnetic field is created around that coil. When the current flow increases, the strength of the magnetic field increases, drawing the spring-biased, movable, magnetic core

toward the pole piece. As the core moves inward, the efficiency of the magnetic circuit is increased, creating an even greater electro-magnetic force. When the core is fully "in", maximum electro-magnetic force is attained, the armature is attracted to the pole piece, unlatching a trip mechanism, thereby opening the contacts. (Fig. 3)

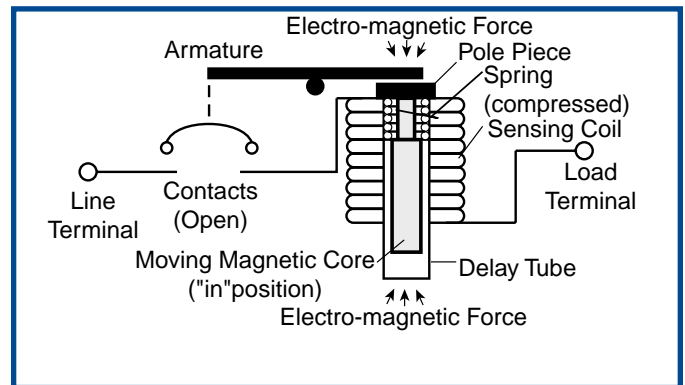

Figure 3 - Moderate Overload with Induced Delay

Under short circuit conditions, the resultant increase in electro-magnetic energy is so rapid, that the armature is attracted without core movement, allowing the breaker to trip without an induced delay. This is called "instantaneous trip". It is a safety feature which results in a very fast trip response when most needed. (Fig. 4)

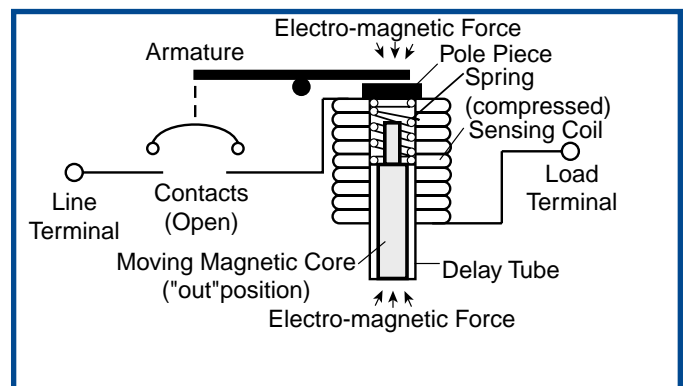

Figure 4 - Short Circuit Condition - No Induced Delay

**How Various Time Delays are Obtained**

Generally speaking, the trip time of a time delay magnetic circuit breaker is directly related to the length of time it takes for the moving metal core to move to the fully "in" position. If the delay tube is filled with air, the core will move rather quickly, and the breaker will trip quickly. This is characteristic of the Ultrashort Delay Curves #11 and #21. Solid state devices, which cannot tolerate even short periods of current overload, should use Instantaneous Curves #10, #20 and #30. These curves have no intentional time delay.

When the delay tube is filled with a light viscosity (temperature stable) fluid, the core's travel to the full "in" position will be intentionally delayed. This results in the slightly longer Medium

Delays #14, 24, 34 and 44, which are used for general purpose applications.

When a heavy viscosity fluid is used, the result will be a very long delay, such as Delay Curve #16, #26, #36 or #46. These curves are commonly used in motor applications to minimize the potential for nuisance tripping during lengthy motor start-ups.

By use of magnetic "shunt" plates within the magnetic circuit, it is possible to divert magnetic flux resulting in higher "inrush withstanding capability" (or high inrush delays). These delays disregard short duration, high pulse surges (typically 8ms or less and up to 25x rated current), characteristic of transformers, switching power supplies and capacitive loads. Delay Curves #42, #44, and #46, are available for these applications.

Hydraulic delay protectors have the added advantage of tripping slightly sooner when operating in higher temperature conditions and slightly longer when cold. This characteristic mirrors the protection needs in most applications. Note that the current required to trip the breaker does not change, just the time delay for tripping.

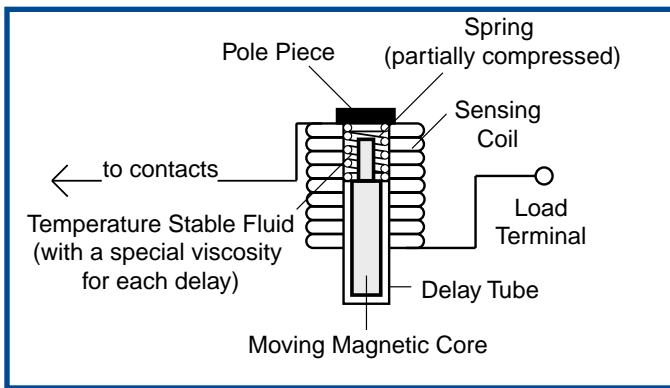

*Rated Current or Less*

**Available Circuit Options**

**Series Trip**

A basic two terminal device is usually used as a combination power switch and overload protector. The contacts and current sensing coil are connected in series with the line and load terminals.

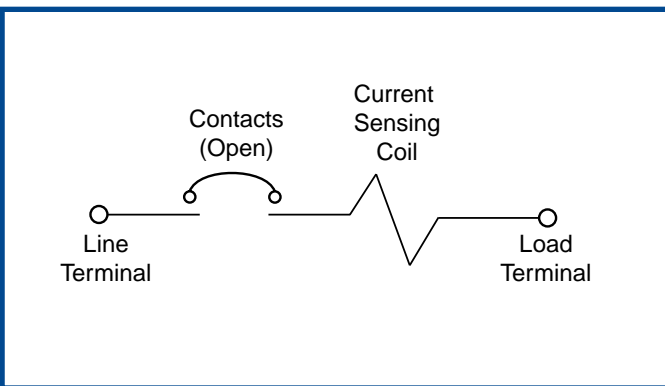

**Series Trip with Auxiliary Switch**

Same as a Series Trip except with the addition of a S.P.D.T. snap-action switch, which is electrically isolated, but mechanically linked to the movement of the main breaker contacts. This switch is commonly used to remotely signal the status of the breaker (ON or OFF/TRIPPED).

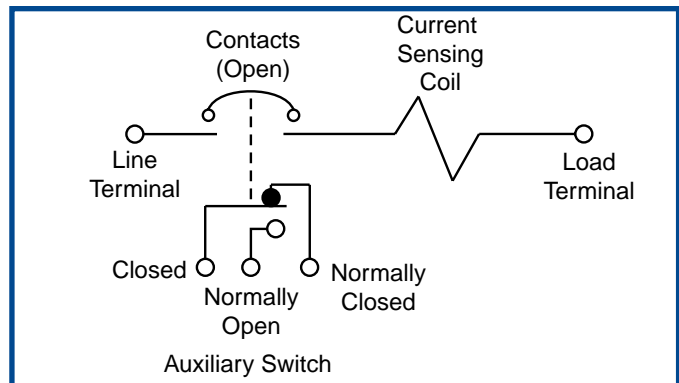

Available Circuit Options

Series Mid-Trip with Auxiliary/Alarm Switch

Similar to “Series Trip with Auxiliary Switch” except the S.P.D.T. auxiliary switch is actuated only upon electrical trip of the breaker. Upon electrical trip, the “N.O.” contact closes and the “N.C.” contact opens. This can be used to remotely signal the “TRIPPED” status of the breaker. Also, upon electrical trip, the handle moves to the “MID” position as opposed to the “full OFF” position typical of other breakers. This gives a specific visual panel indication of a “TRIPPED” breaker as compared to one which is merely turned OFF.

Series Mid-Trip is also available without Auxiliary/Alarm Switch.

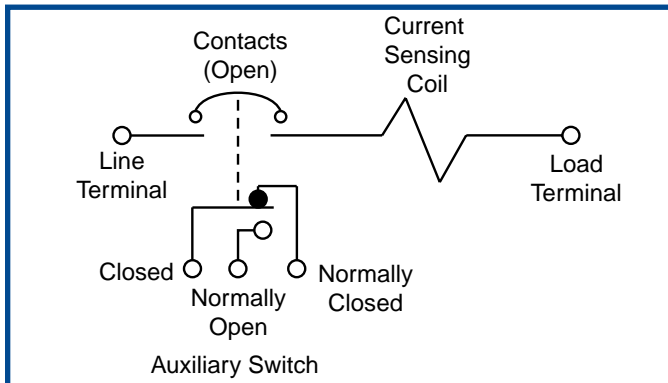

Series Trip with Remote Shutdown

(For “dump” circuit or “panic” circuit applications). Same as a Series Trip but with an additional (self-interrupting) “voltage coil” pole (usually of opposite polarity) for remote shutdown. In the example, a momentary voltage pulse to Pole 2 will shut down both Pole 1 and Pole 2. Because the voltage coil in Pole 2 is self-interrupting, no additional components, such as auxiliary switches, etc., are required in that circuit. Approximately 4 watts minimum is required to activate the voltage coil pole. This extra pole configuration is usually required by World Approval Agencies. Consult factory for this circuit.

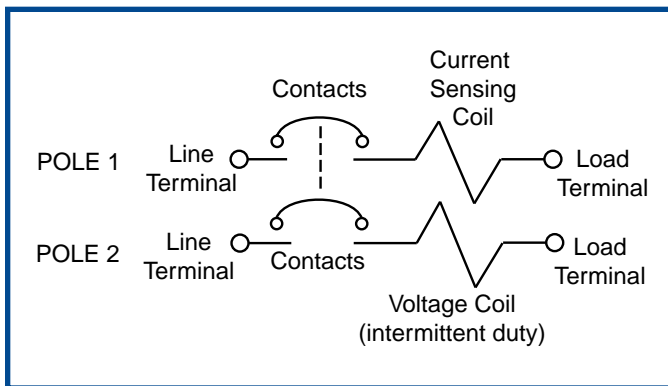

Dual Coil with Remote Shutdown

Similar to “Series Trip with Remote Shutdown” except an extra pole is NOT required. A Dual Coil breaker has two coils in the space normally occupied by a single coil. A current coil is used for overload protection and the instant trip voltage coil can be used for remote shutdown. Approximately 30 watts minimum is required to activate this type of voltage coil.

Two Dual Coil options are available. The most common is the “Relay Trip Dual Coil”, a four terminal device in which the voltage coil circuit is electrically isolated from the current coil circuit. This allows the triggering of the voltage coil from an independent voltage source separate from line voltage. As such, a DC pulse to the voltage coil can be used to shutdown a primary high energy AC circuit. However, because voltage coils are rated for intermittent duty, provisions must be made to disconnect the power source from the voltage coil after tripping.

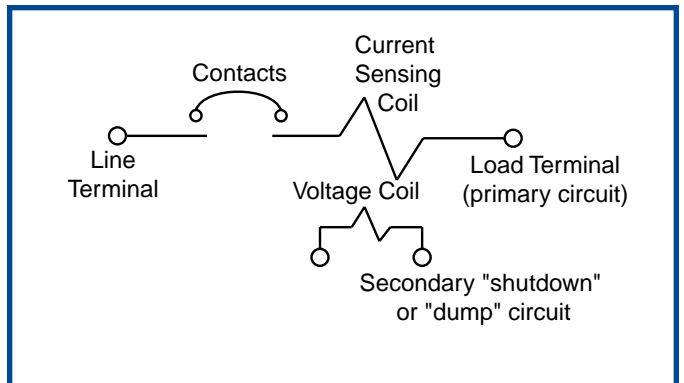

The other circuit option is the “Shunt Trip Dual Coil”, a three terminal device with one side of the voltage coil internally connected to the primary circuit. The other side of the voltage coil is connected to an external third terminal on the bottom of the breaker. This circuit option uses line voltage for dual coil activation, saving wiring costs and resulting in a self-protecting voltage coil.

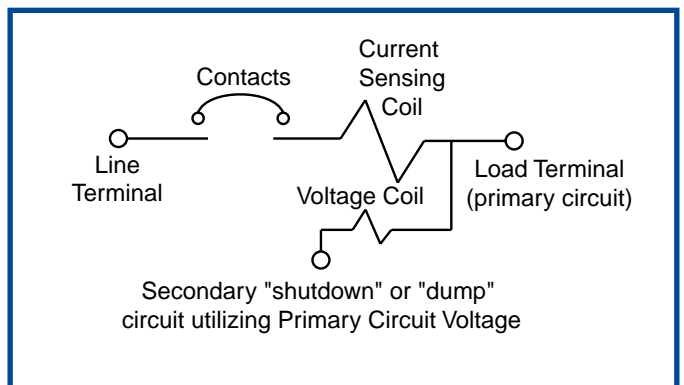

Care must be taken to avoid mis-wiring of the primary and secondary (voltage coil) circuits. Mis-wiring could lead to damage to the voltage coil and/or its power source.

Available Circuit Options

Switch Only

Same as a Series Trip, but without a sensing coil. Provides low cost, heavy-duty switch capability when overload protection is not needed. "Switch Only" is available with and without an auxiliary switch.

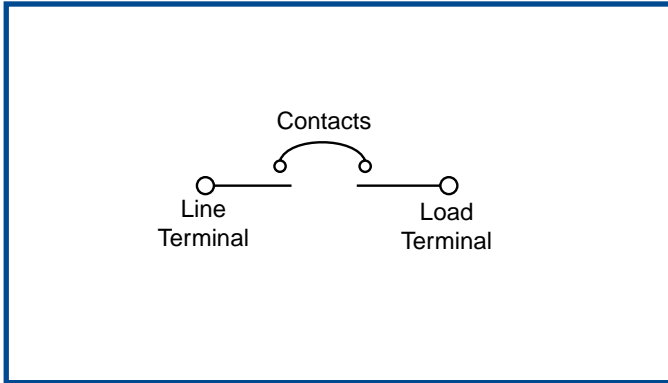

Relay Trip

A four terminal device in which the contact and coil circuits are electrically isolated but mechanically linked. An overload in the coil circuit will cause the contact circuit to open. These circuits may be of opposite polarity. Commonly used in dump circuit, panic circuit, and remote shutdown applications. (Note: World Approval Agencies may require a more electrically isolated voltage coil pole for this function - Ref. "Series Trip with Remote Shutdown" circuit option.)

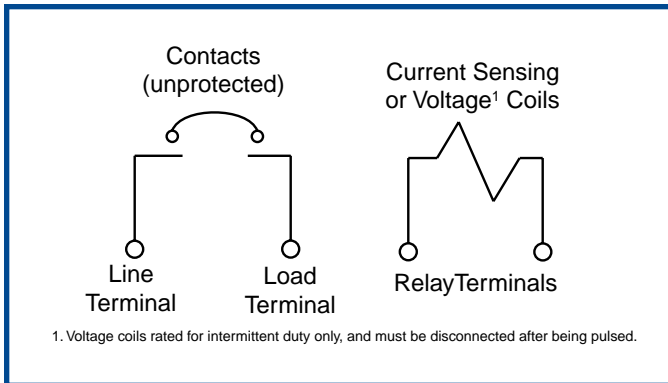

Shunt Trip

A three terminal device similar to "Series Trip", but with the addition of a third terminal between the contacts and the coil. This circuit is usually used to control two separate loads (A&B) from the same power source, while sensing overload current in only one load (B). It should be noted that overload protection is not provided in the load (A) circuit, and if needed, must be provided by other means. Also, the sum of the current in circuit A & B must not exceed the contact rating of the device.

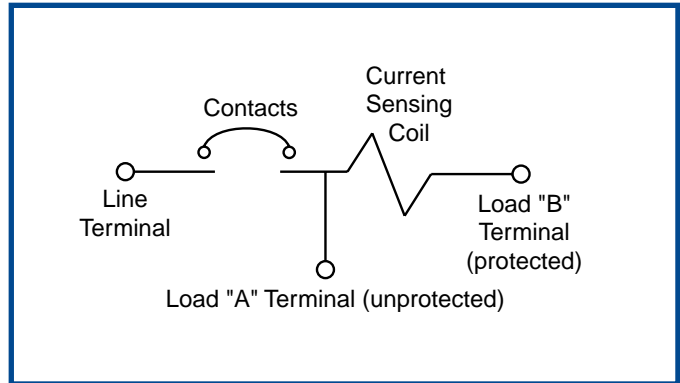

Another application possibility occurs when a voltage coil (rated for line voltage) is used. Here the load (B) terminal is connected in series with a N.O. push-button switch or similar control device. With this, a line voltage pulse through the coil can be used as a means of remotely opening the load (A) circuit. Because the voltage coil is self-interrupting, no additional components, such as auxiliary switches, etc., are needed in the load (B) circuit.

